

Service
Service
Service



Service Manual

TABLE OF CONTENTS

	Chapter
Technical Specification.....	1
Safety Instructions.....	2
Instruction for Use.....	3
Mechanical Instructions.....	4
Troubleshooting & Service tips.....	5
Overall block diagram.....	6
Overall wiring diagram.....	7
Electrical diagram.....	8
Component layout.....	9
Service part list.....	10
Revision list.....	11

©Copyright 2005 Philips Consumer Electronics B.V. Eindhoven, The Netherlands
All rights reserved. No part of this publication may be reproduced, stored in a
retrieval system or transmitted, in any form or by any means, electronics,
mechanical, photocopying, or otherwise without the prior permission of Philips

3141 785 30565

1.0 TECHNICAL SPECIFICATION and SERVICE HINT

General

Dimensions (WxLxH):	19 x 14.6 x 2.9 cm 7.48 x 5.75 x 1.14 inches
Weight:	1kg / 2.2 lb
Power supply:	DC 9V 2.2A
Power consumption:	≤20W
Operating temp. range:	0 - 50°C (32 ~ 122°F)
Laser wavelength:	650nm
Video system:	NTSC / PAL / AUTO
Frequency response:	20Hz ~ 20KHz ± 1dB
Signal/noise ratio:	≥85dB
Audio distortion + noise:	≤80(1KHz)
Channel separation:	≥85dB
Dynamic range:	≥80dB
Output	
Audio out (analog audio):	Output level: 2V ± 10%
Load impedance:	10KΩ
Video out Output level:	1Vp - p ± 20%
Load impedance:	75Ω
Current consumption	

DC-IN SUPPLY (9.0V)	
Battery Charging Current	1.2A typ.
BATT. SUPPLY (7.2V)	
Power Off	0A
Playback with TFT on	<1.2A typ.
Playback without TFT on	<600mA
Battery playtime	>2.5hrs

Headphone out (headphone output load 2x16ohm)

Maximum output power:	>10mW
Frequency response:	20Hz - 20kHz
SNR (A-wght):	80dB typ.
THD (1kHz):	<1%
Left-Right Channel Separation:	32dB typ.
Left-Right Channel Balance:	1dB

Supported disc type

DVD video discs:



Video CD:



Audio CD:



In addition, this unit can play DVD+R & DVD+RW and CD-R & CD-RW that contains audio titles or MP3 or JPEG files.

You cannot play disc other than the above listed. (CVD, CD-ROM, CD-Extra, CD-G and CD-I discs cannot be played on this DVD player)

Software upgrades

For the best performance of your DVD Portable. Check www.philips.com/support for latest software upgrades available.

To check the software version of your DVD Portable.

1. Press the SETUP key to enter the setup menu.
2. Press RETURN and then press 1, 2 and 3 on the remote control.
3. The display will show the software version as the date of which the software was built on the bottom of the screen. E.g. 050303

Procedure on how to upgrade the software of the DVD Portable

1. Download the latest software from the Philips support site.
2. Unzipped the files and then burn it onto a CD ROM then playback the CD ROM on the DVD Portable.

Pixel specification

≤ 4 (max. 0 bright dots and 3 dark dots)

2.0 SAFETY INSTRUCTIONS

(GB) WARNING

All ICs and many other semi-conductors are susceptible to electrostatic discharges (ESD). Careless handling during repair can reduce life drastically.
When repairing, make sure that you are connected with the same potential as the mass of the set via a wrist wrap with resistance. Keep components and tools also at this potential.

ESD



(NL) WAARSCHUWING

Alle IC's en vele andere halfgeleiders zijn gevoelig voor electrostatische ontladingen (ESD).
Onzorgvuldig behandelen tijdens reparatie kan de levensduur drastisch doen verminderen. Zorg ervoor dat u tijdens reparatie via een polsband met weerstand verbonden bent met hetzelfde potentiaal als de massa van het apparaat.
Houd componenten en hulpmiddelen ook op ditzelfde potentiaal.

(F) ATTENTION

Tous les IC et beaucoup d'autres semi-conducteurs sont sensibles aux décharges statiques (ESD).
Leur longévité pourrait être considérablement écourtée par le fait qu'aucune précaution n'est prise à leur manipulation.
Lors de réparations, s'assurer de bien être relié au même potentiel que la masse de l'appareil et enfiler le bracelet serti d'une résistance de sécurité.
Veiller à ce que les composants ainsi que les outils que l'on utilise soient également à ce potentiel.

(D) WARNUNG

Alle ICs und viele andere Halbleiter sind empfindlich gegenüber elektrostatischen Entladungen (ESD).
Unsorgfältige Behandlung im Reparaturfall kann die Lebensdauer drastisch reduzieren.
Veranlassen Sie, dass Sie im Reparaturfall über ein Pulsarmband mit Widerstand verbunden sind mit dem gleichen Potential wie die Masse des Gerätes.
Bauteile und Hilfsmittel auch auf dieses gleiche Potential halten.

(I) AVVERTIMENTO

Tutti IC e parecchi semi-conduttori sono sensibili alle scariche statiche (ESD).
La loro longevità potrebbe essere fortemente ridotta in caso di non osservazione della più grande cauzione alla loro manipolazione.
Durante le riparazioni occorre quindi essere collegato allo stesso potenziale che quello della massa dell'apparecchio tramite un braccialetto a resistenza.
Assicurarsi che i componenti e anche gli utensili con quali si lavora siano anche a questo potenziale.

(GB)

Safety regulations require that the set be restored to its original condition and that parts which are identical with those specified, be used.

"Pour votre sécurité, ces documents doivent être utilisés par des spécialistes agréés, seuls habilités à réparer votre appareil en panne".

(NL)

Veiligheidsbepalingen vereisen, dat het apparaat bij reparatie in zijn oorspronkelijke toestand wordt teruggebracht en dat onderdelen, identiek aan de gespecificeerde, worden toegepast.



(F)

Les normes de sécurité exigent que l'appareil soit remis à l'état d'origine et que soient utilisés les pièces de rechange identiques à celles spécifiées.

(GB) Warning !

Invisible laser radiation when open.
Avoid direct exposure to beam.

(D)

Bei jeder Reparatur sind die geltenden Sicherheitsvorschriften zu beachten. Der Originalzustand des Geräts darf nicht verändert werden; für Reparaturen sind Original-Ersatzteile zu verwenden.

(S) Varning !

Osynlig laserstrålning när apparaten är öppnad och spärrar är urkopplad. Betrakta ej strålen.

(I)

Le norme di sicurezza esigono che l'apparecchio venga rimesso nelle condizioni originali e che siano utilizzati i pezzi di ricambio identici a quelli specificati.

(SF) Varoitus !

Avatussa laitteessa ja suojalukituksen ohitettaessa olet alltiina näkymättömälle laserisäteilylle. Älä katso säteeseen!

(DK) Advarse !

Usynlig laserstråling ved åbning når sikkerhedsafbrydere er ude af funktion. Undgå udsættelse for stråling.

"After servicing and before returning set to customer perform a leakage current measurement test from all exposed metal parts to earth ground to assure no shock hazard exist. The leakage current must not exceed 0.5mA."

2.1 ESD PROTECTION

- レンズには絶対に触れないでください。
- DO NOT TOUCH THE LENS.
- LINSE NICHT BRÜHREN.
- NE PAS TOUCHER LA LENTILLE.

When the power supply is being turned on, you may not remove this laser cautions label. If it removes, radiation of laser may be received.

PREPARATION OF SERVICING

Pickup Head consists of a laser diode that is very susceptible to external static electrocity.

Although it operates properly after replacement, if it was subject to electrostatic discharge during replacement, its life might be shortened. When replacing, use a conductive mat, soldering iron with ground wire, etc. to protect the laser diode form damage by static electricity.

And also, the LSI and IC are same as above.

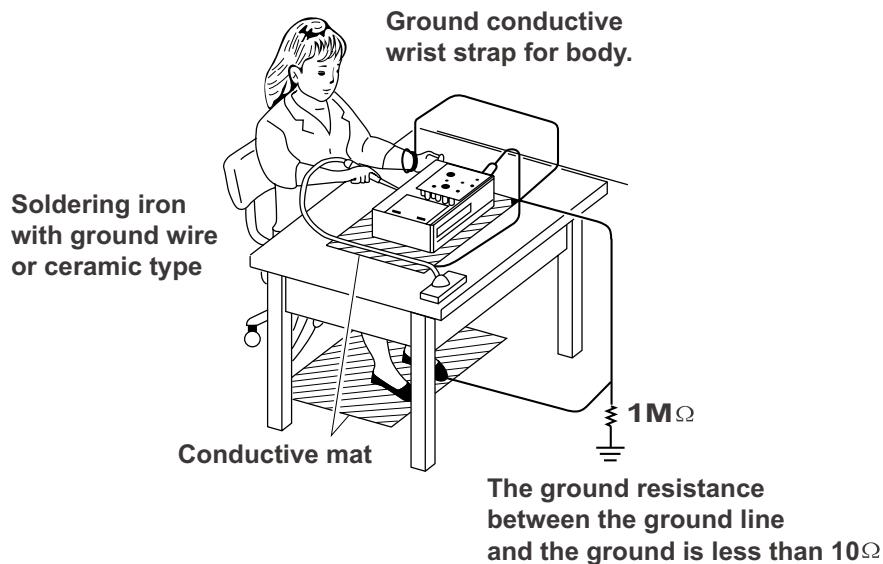

SAFTY NOTICE

SAFTY PRECAUTIONS

LEAKAGE CURRENT CHECK

Plug the AC line cord directly into a 120V AC outlet (do not use an isolation transformer for this check). Use an AC voltmeter, having 5000Ω per volt or more sensitivity. Connect a 1500Ω 10W resistor, paralleled by a $0.15\mu\text{F}$ 150V AC capacitor between a known good earth ground (water pipe, conduit, etc.) and all exposed metal parts of cabinet (antennas, handle bracket, metal cabinet screwheads, metal overlays, control shafts, etc.).

Measure the AC voltage across the 1500Ω resistor. The test must be conducted with the AC switch on and then repeated with the AC switch off. The AC voltage indicated by the meter may not exceed 0.3V. A reading exceeding 0.3V indicates that a dangerous potential exists, the fault must be located and corrected. Repeat the above test with the DVD VIDEO PLAYER power plug reversed. NEVER RETURN A DVD VIDEO PLAYER TO THE CUSTOMER WITHOUT TAKING NECESSARY CORRECTIVE ACTION.

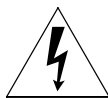
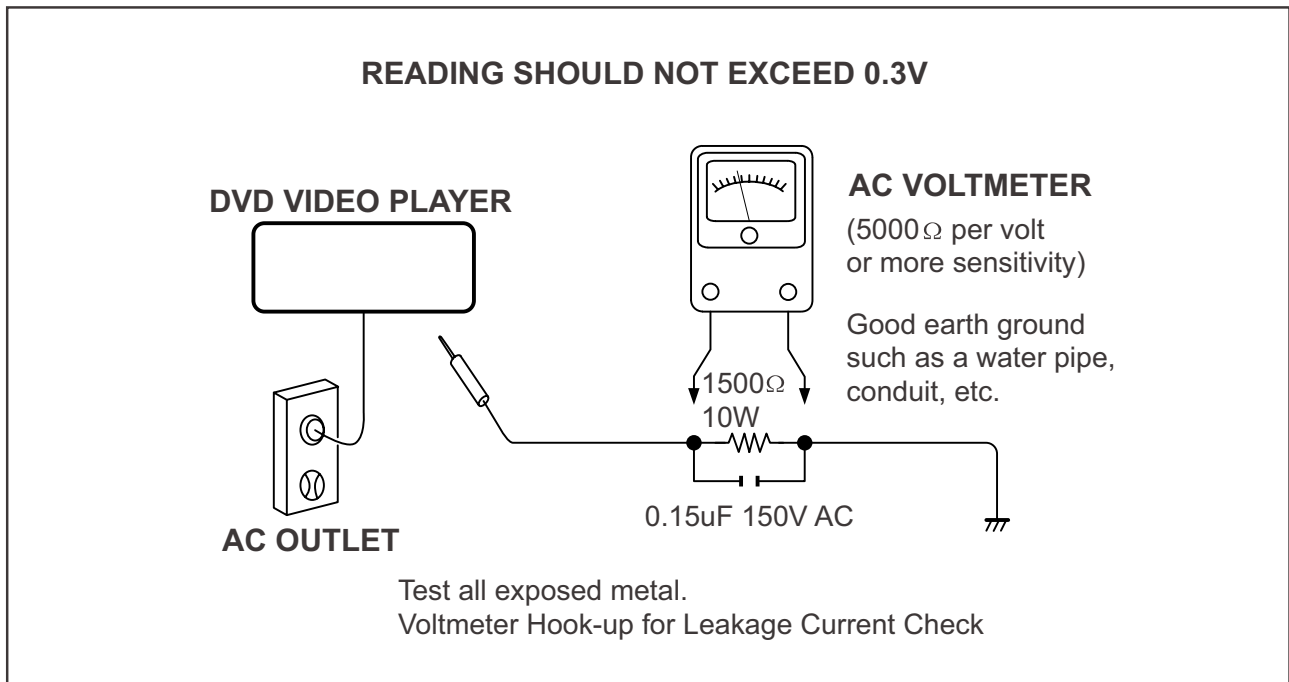

The lightning flash with arrowhead symbol, within an equilateral triangle, is intended to alert the user to the presence of uninsulated "dangerous voltage" within the product's enclosure that may be of sufficient magnitude to constitute a risk of electric shock to persons.



The exclamation point within an equilateral triangle is intended to alert the user to the presence of important operating and maintenance (servicing) instructions in the literature accompanying the appliance.

3.0 INSTRUCTIONS FOR USE

English

Front of player

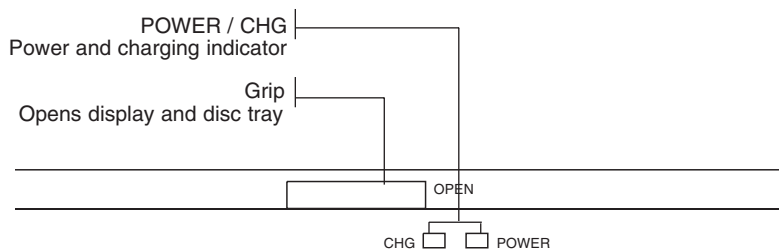

Left of player

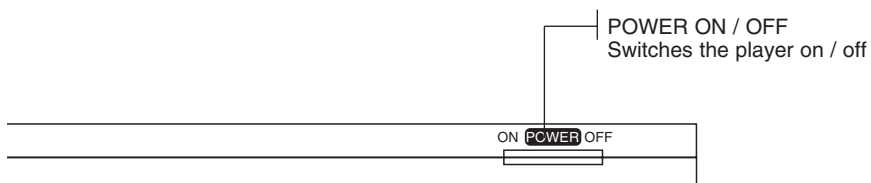

Right of player

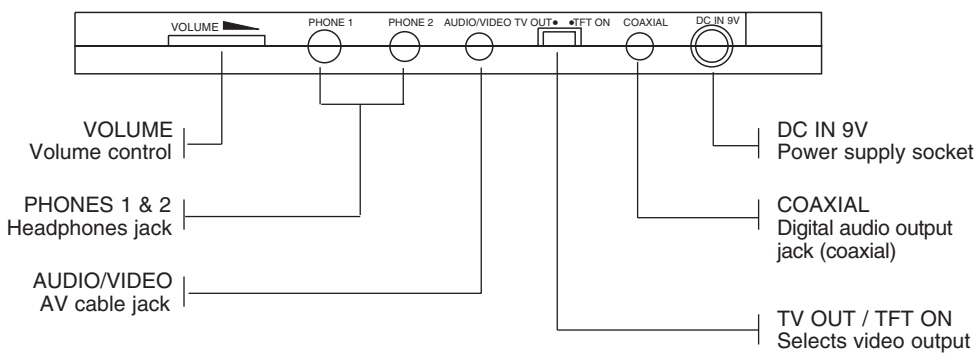

Disc tray

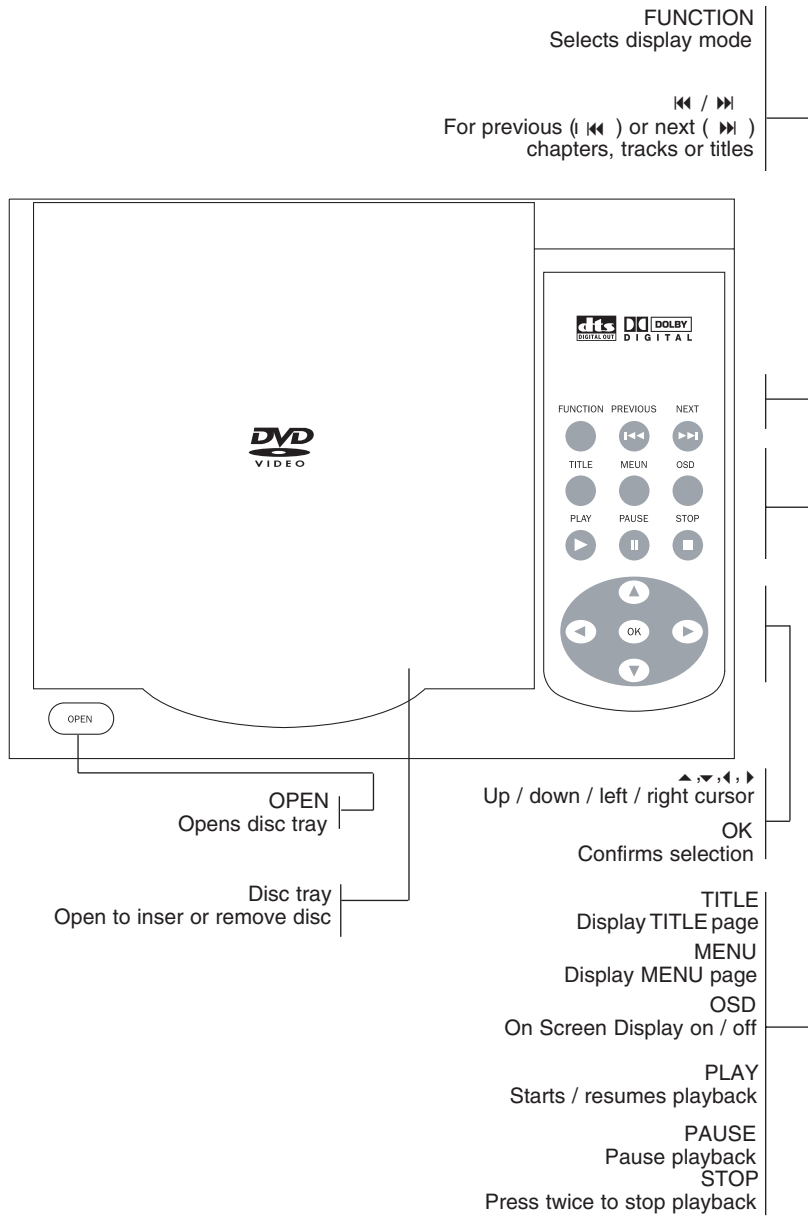

Remote control

OSD
On Screen Display on / off

LANGUAGE
Language selector

AUDIO
Audio language selector

SCAN
Playback of the first 10 seconds of each chapter / index on the disc

BOOKMARK
Selects bookmark options

MENU
Displays MENU page

TITLE
Displays TITLE page

⏮
Previous chapter, track or title

⏪
Search backward

PLAY / OK
Confirms selection and starts playback

STOP
Press twice to stop playback

PAUSE
Pause playback

0-9
Numerical keypad

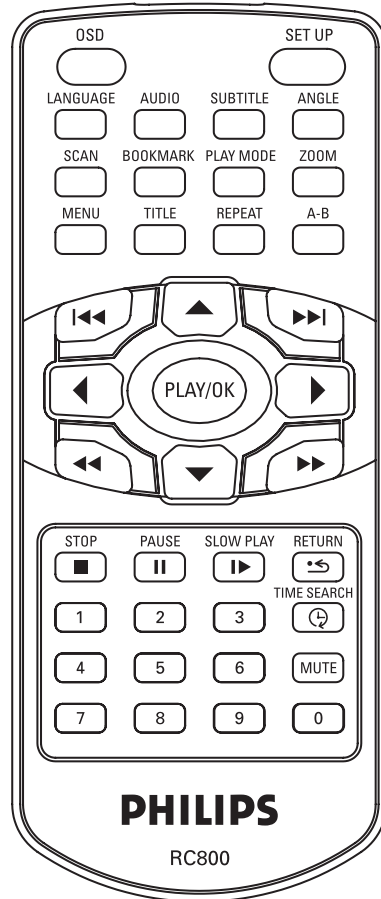

SETUP
Enters SETUP menu

SUBTITLE
Subtitle language selector

ANGLE
Selects DVD camera angle

PLAY MODE
Selects play order options

ZOOM
Enlarges / chapter / video image

REPEAT
Repeats chapter / title / disc

A - B
To repeat or loop a sequence in a title

⏭
Next chapter, track or title

⏩
Search forward

⏮, ⏪, ⏩, ⏭
Up / down / left / right cursor

SLOW PLAY
Slow motion / Frame by frame playback

RETURN
For VCD menu page

TIME SEARCH
Searches by time

MUTE
Muting player volume

4.0 Mechanical instructions

1. Back View as Fig.1

Remove screws to Disassemble the base



Fig.1



2. Soldered short pattern for laser diode as Fig.2

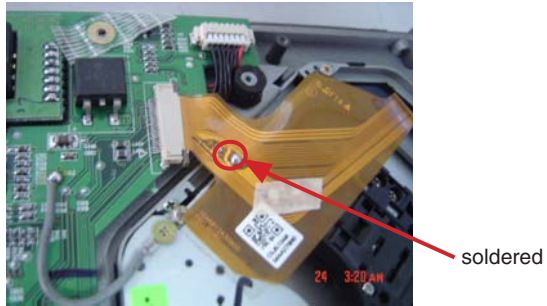

Fig.2

3. Disassemble the DVD drive and main board as Fig.3,4

Disconnect the DVD drive and main board

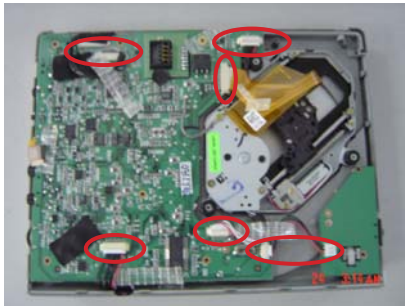

Fig.3

Disassemble the key board and other parts



Fig.4

5. Remove top cover as Fig.5



Fig.5

6. Disassemble the IF board and HV board as Fig.6



Fig.6

7. Detach the LCD TFT as Fig.7

Take off the screws to remove LCD TFT



Fig.7

5.0 TROUBLESHOOTING & SERVICE TIPS

5.1 Procedure to change regioncode

1. Power on player and open DVD Door.
2. Press <Set Up> at Remote Control. In <Set Up Menu> select <Preferences> and press <OK>.
3. For PET700 - Press successively 2 5 2 3 1 5.◀.▼.
4. Display will show <Region Code 2> for Europe:
5. Press key to input preference region code (see below table).
6. Switch off and re-switch on the product.
7. Verify Region code change done.

Region Code	Region
1	USA
2	EUROPE
3	ASIA PACIFIC
4	AUSTRALIA, NEW ZEALAND, LATAM
5	RUSSIA, INDIA
6	CHINA

REMARKS:

1. Password is **CONFIDENTIAL**.

2. Region code is printed on product type plate. Due to DVD legislation region codes different to assigned region may not be released.

5.0 TROUBLESHOOTING & SERVICE TIPS

SYMPTOM: NO POWER, NO GREEN LED

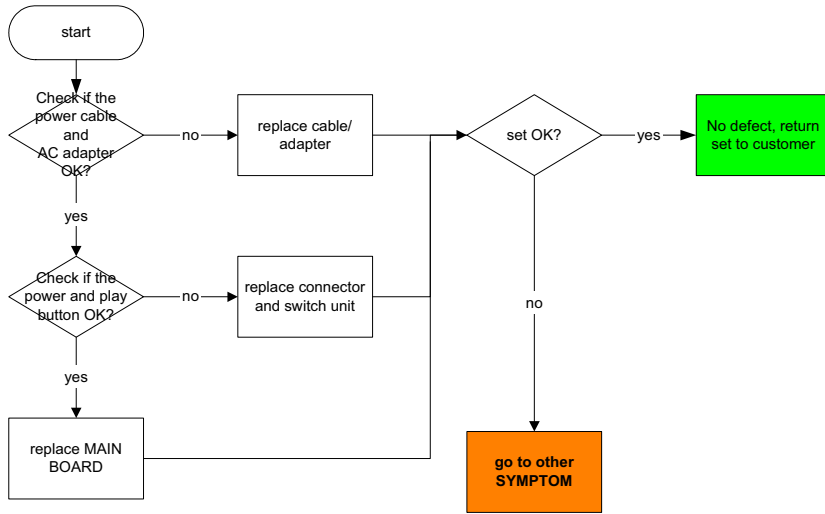

SYMPTOM: NO IMAGE OR SOUND COMES OUT FROM THE EXTERNAL OUTPUT

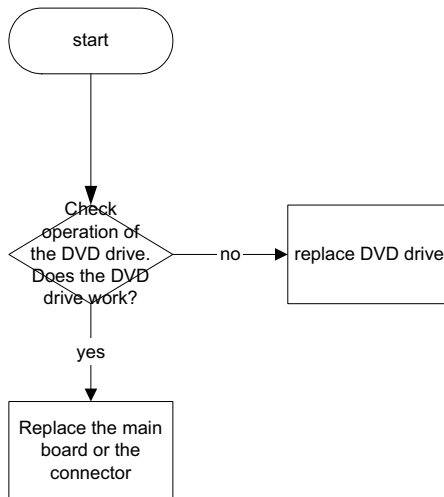

5.0 TROUBLESHOOTING & SERVICE TIPS

SYMPTOM: THE INITIAL SCREEN IS NOT DISPLAYED ON THE LCD

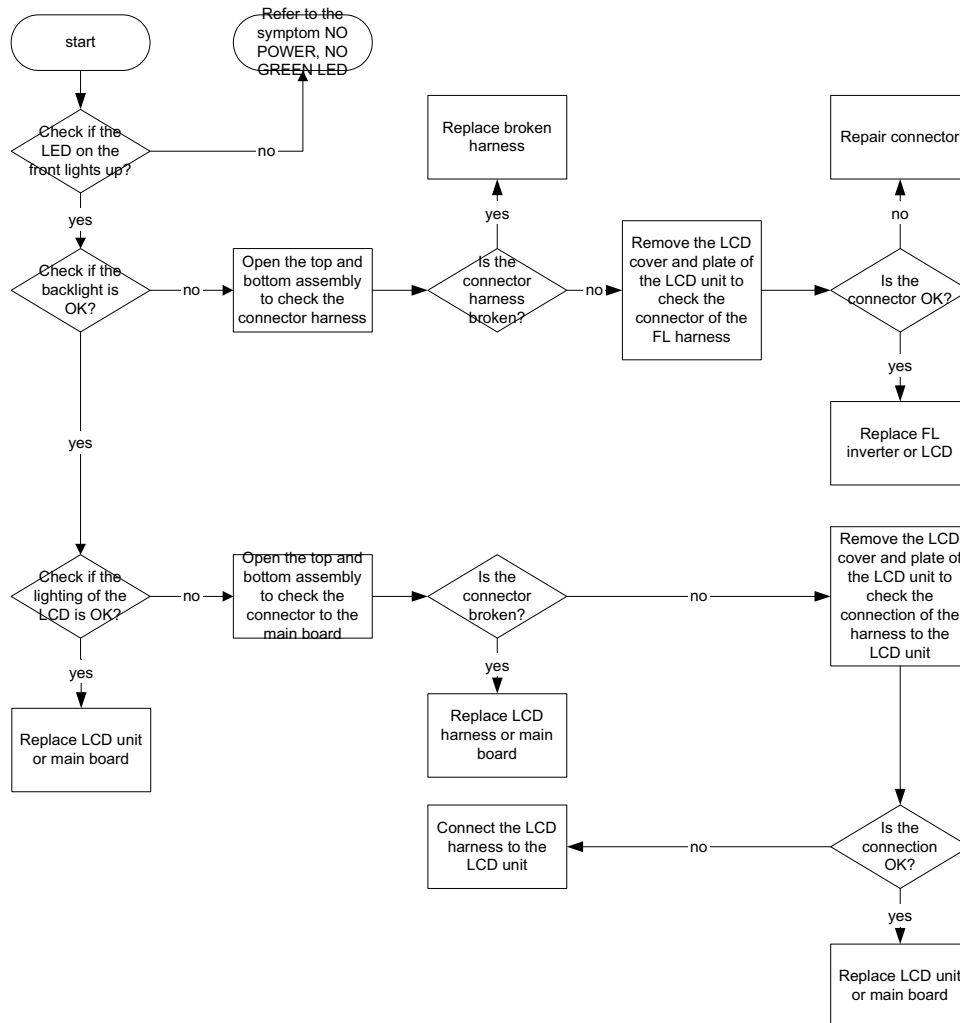

SYMPTOM: NO IMAGE OR SOUND COMES OUT FROM THE EXTERNAL INPUT

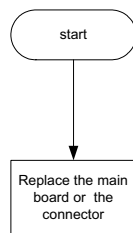

5.0 TROUBLESHOOTING & SERVICE TIPS

SYMPTOM: THE DVD DRIVE DOES NOT WORK

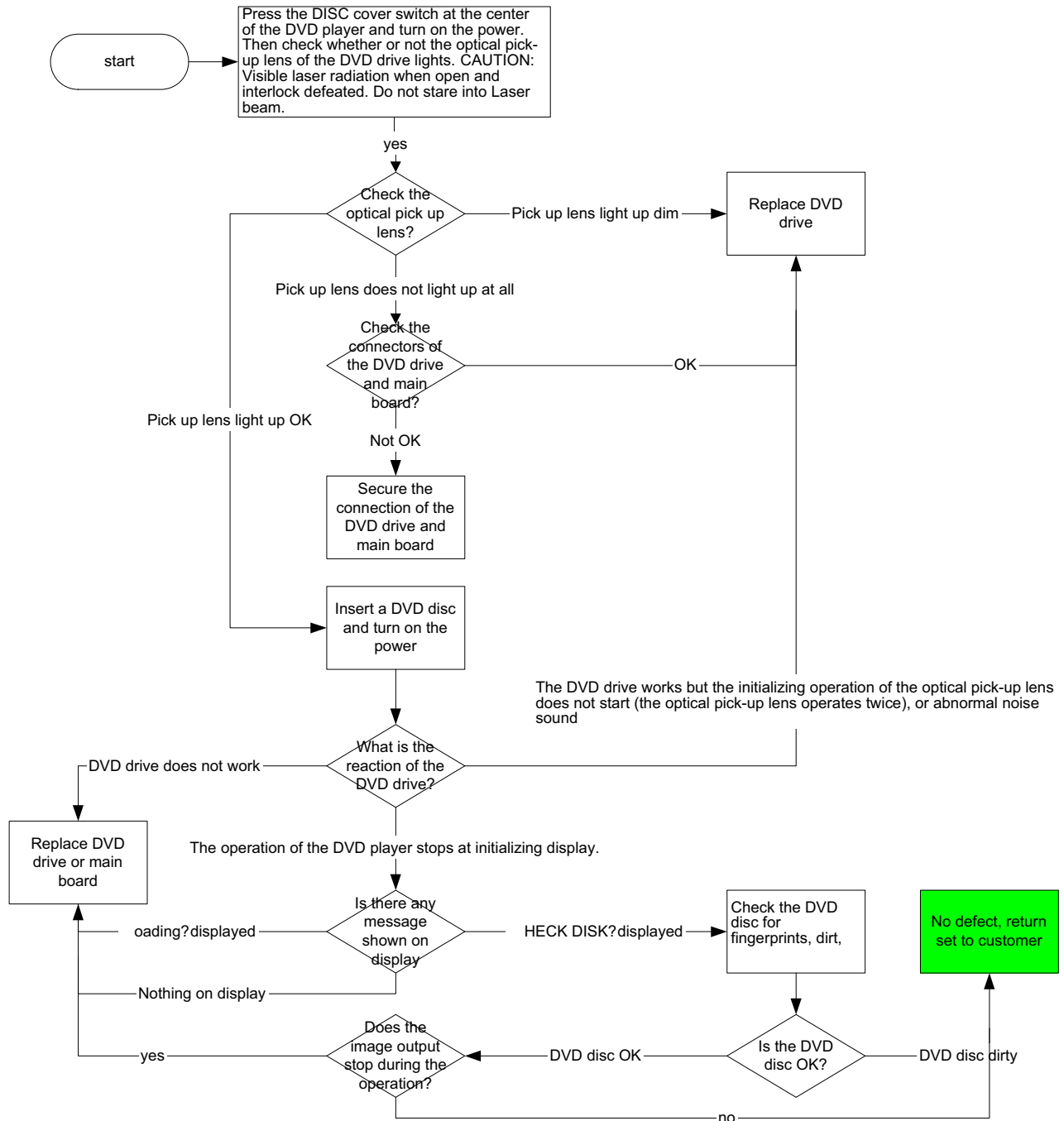

5.0 TROUBLESHOOTING & SERVICE TIPS

SYMPTOM: THE DVD DRIVE DOES NOT OPERATE WITH BATTERY

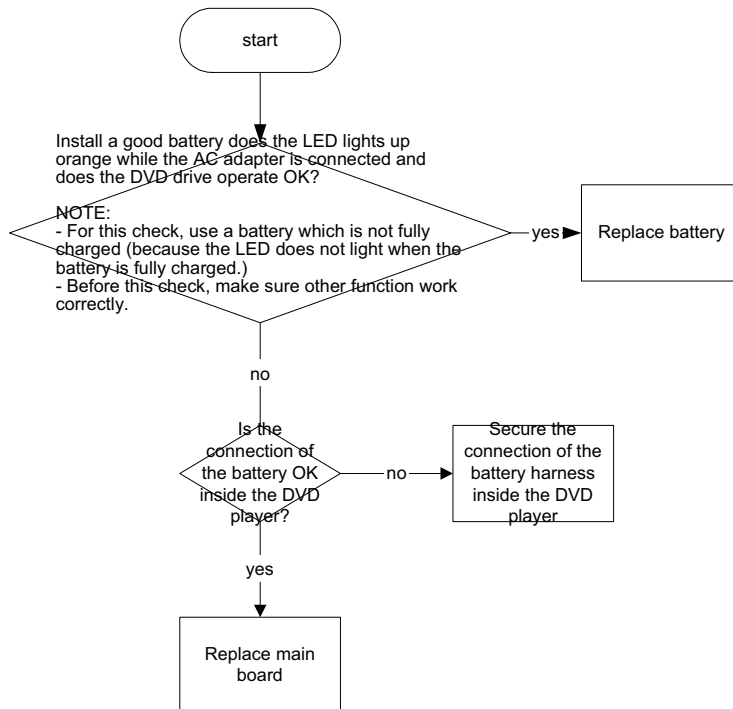

SYMPTOM: NO SOUND COMES FROM THE HEADPHONES

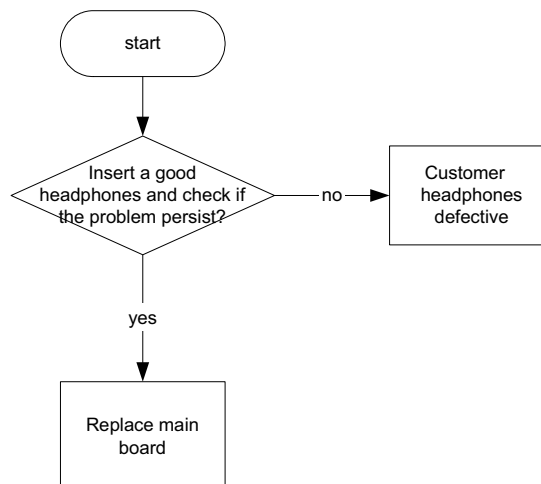

5.0 TROUBLESHOOTING & SERVICE TIPS

SYMPTOM: NO SOUND COMES FROM THE HEADPHONES

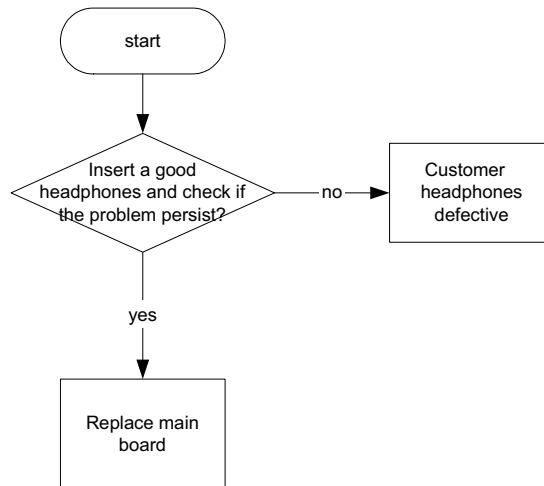

6.0 OVERALL BLOCK DIAGRAM

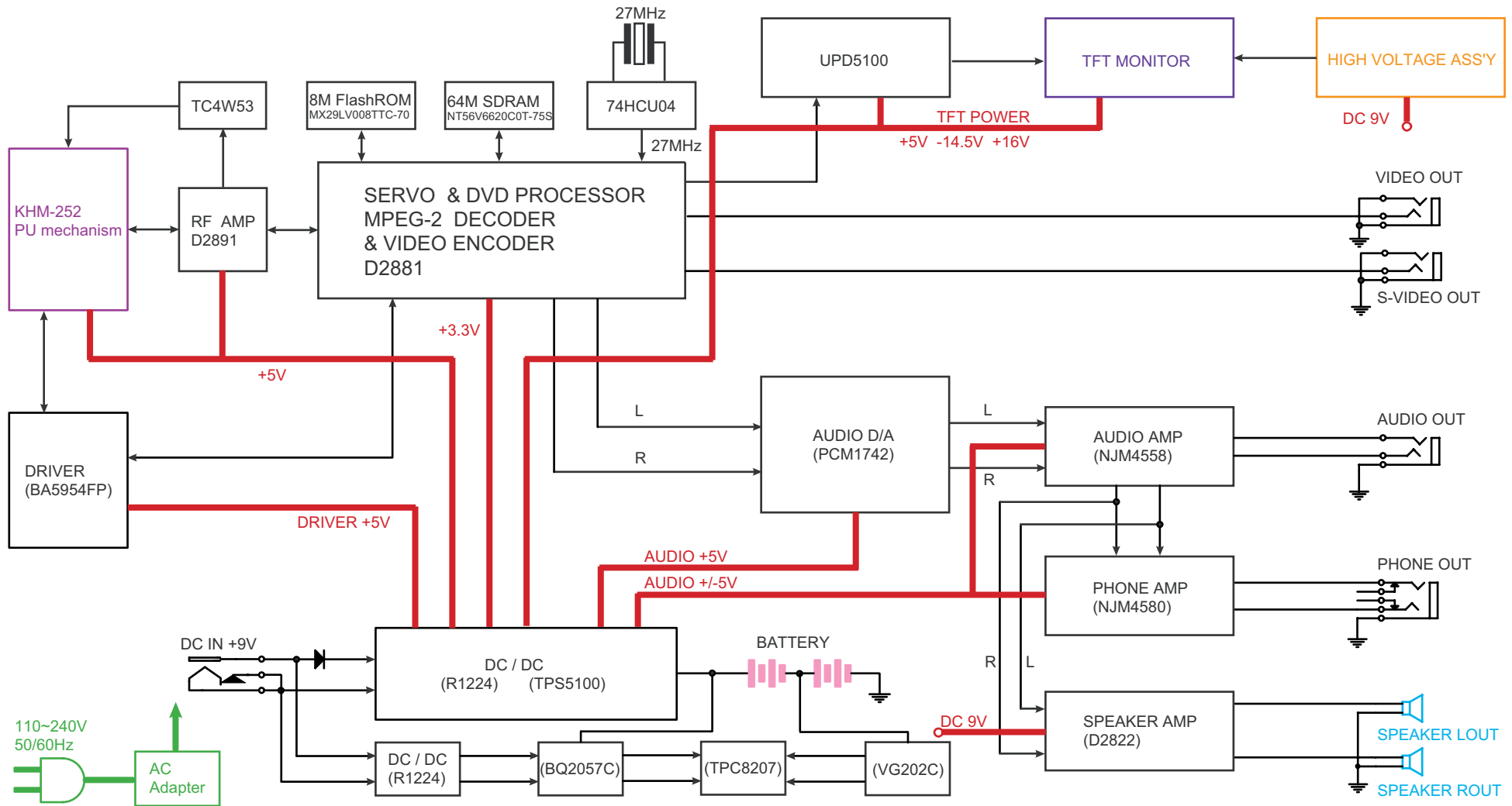

7.0 Overall wiring diagram

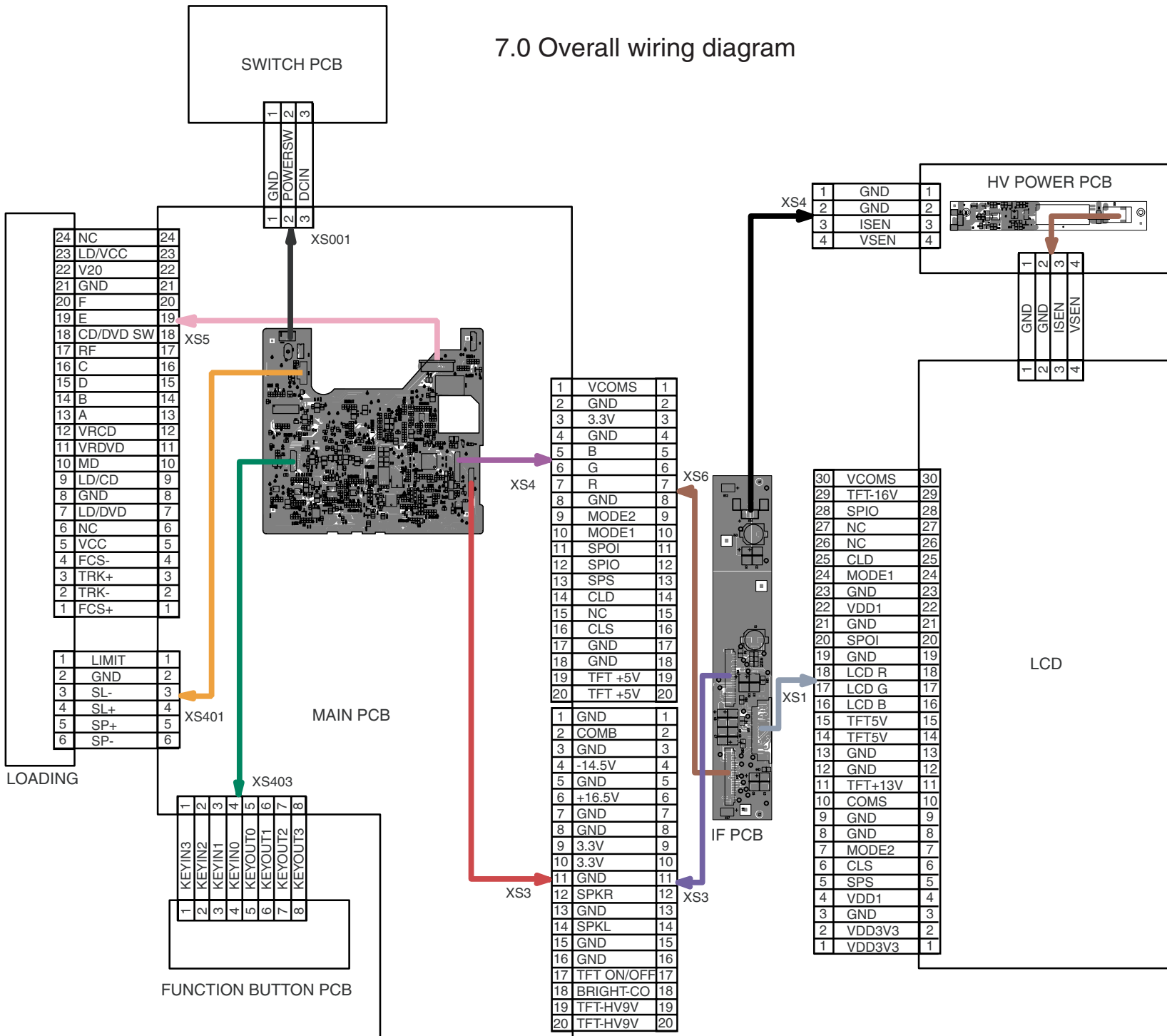

8.0 ELECTRICAL DIAGRAM

DC POWER CIRCUIT DIAGRAM

caution: REPLACE PUSE WITH SAME TYPE AND RATING

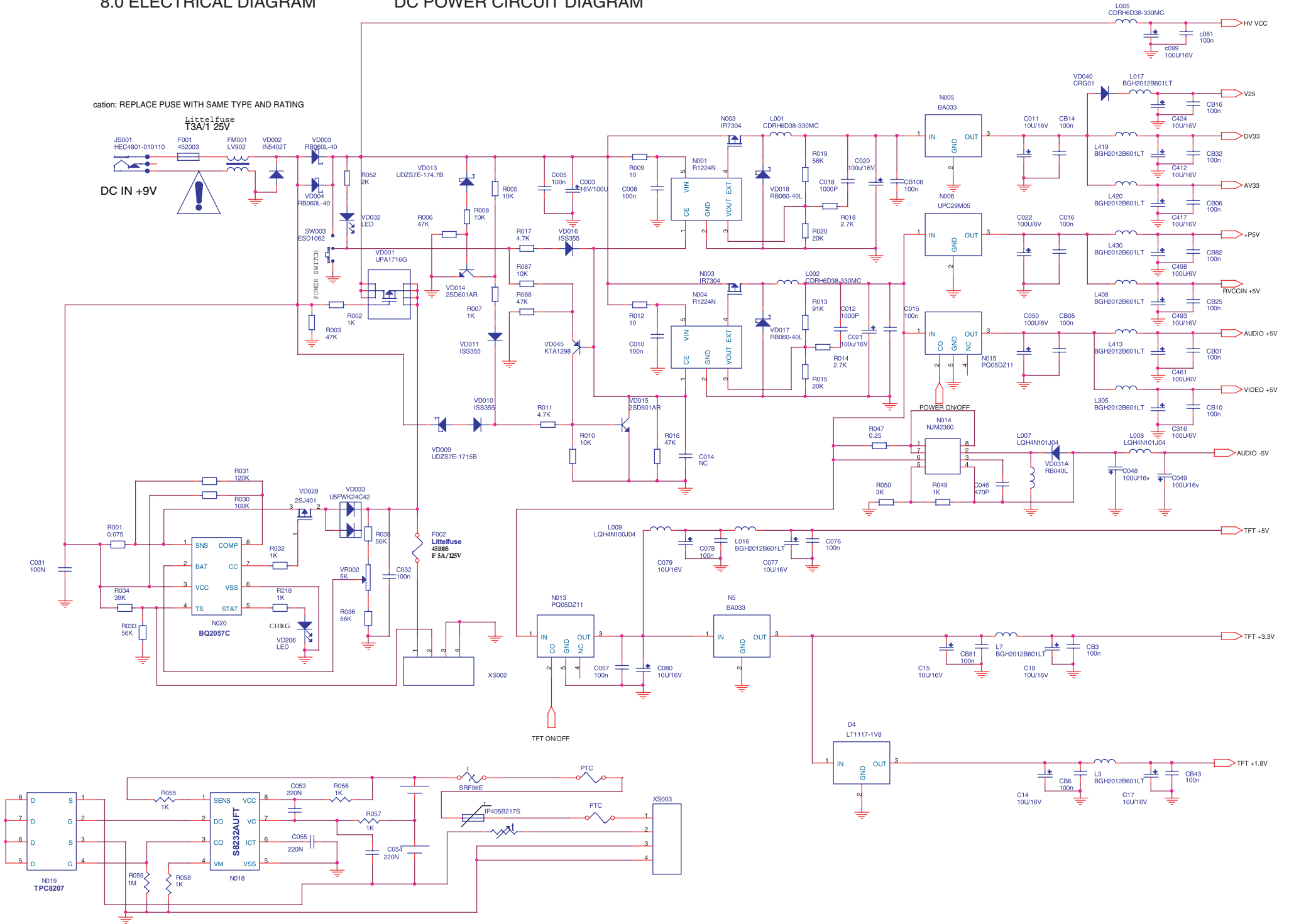

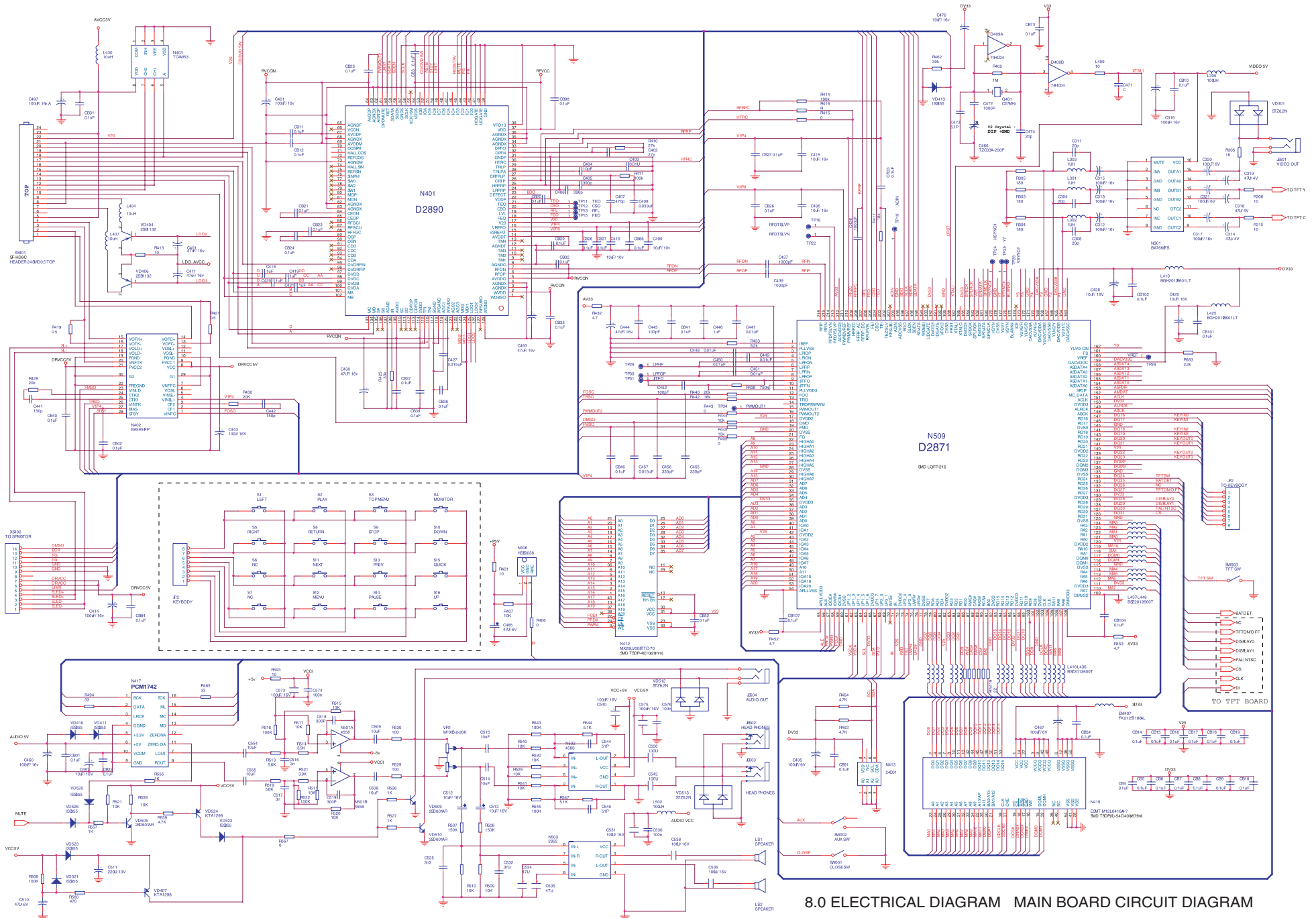

8.0 ELECTRICAL DIAGRAM MAIN BOARD CIRCUIT DIAGRAM

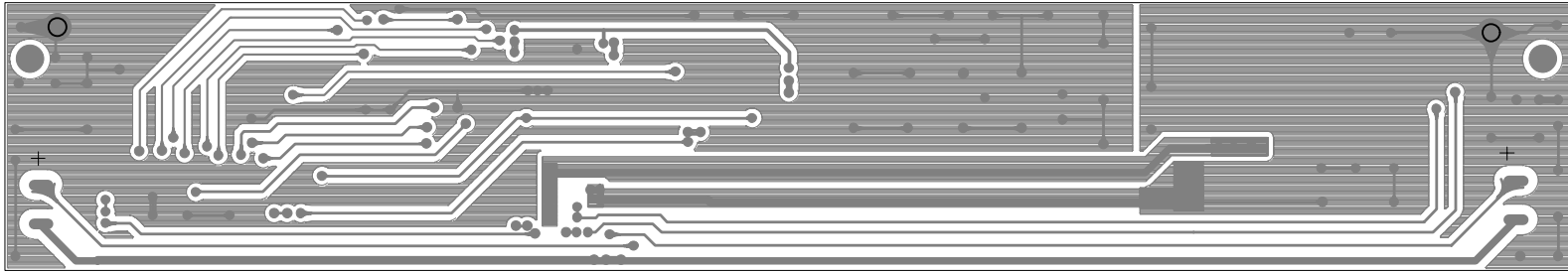
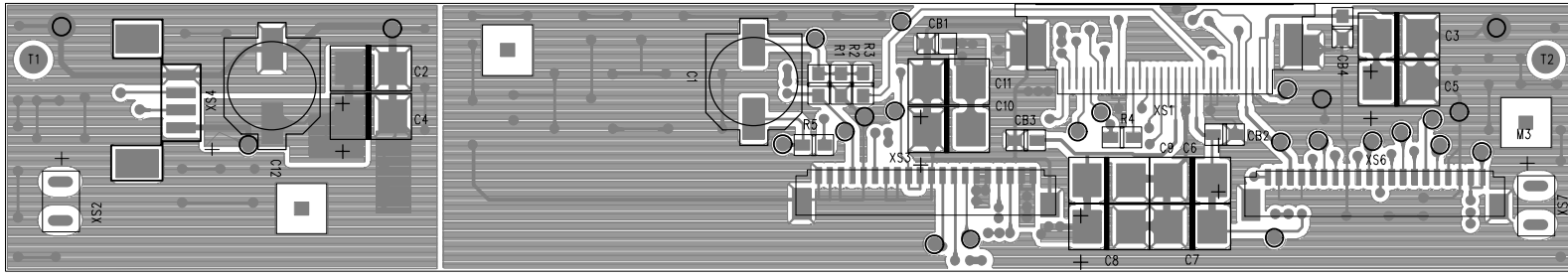

DVD1731T-AS IF PCB BOARD DIAGRAM

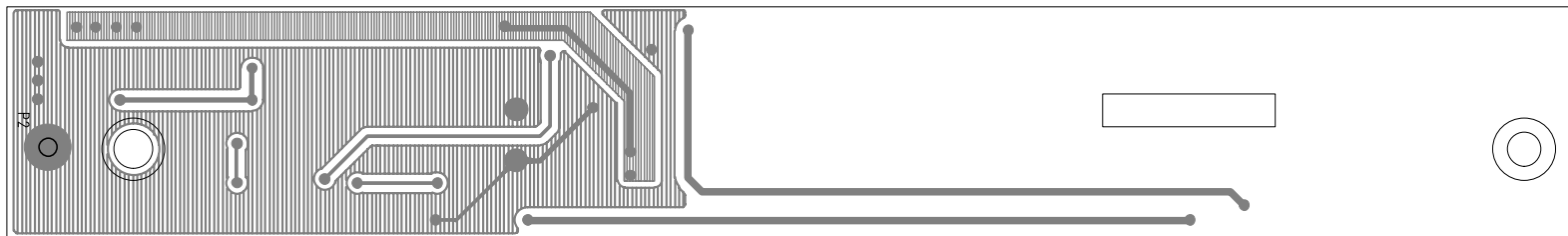
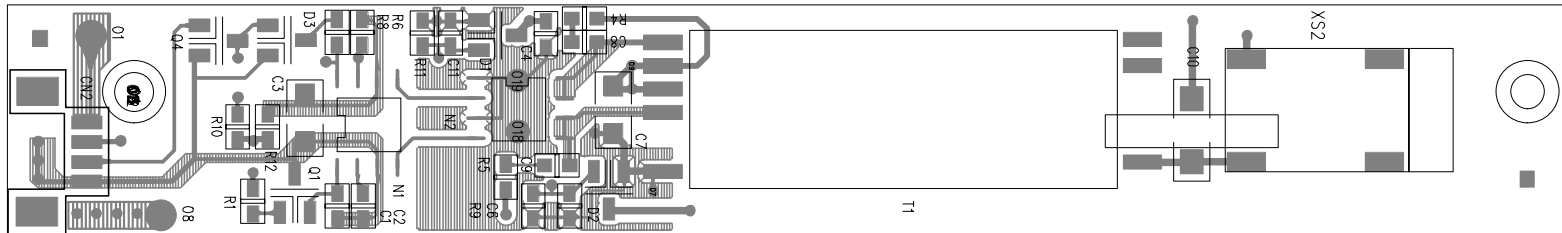

9.0 COMPONENT LAYOUT DVD1650H HV PCB BOARD DIAGRAM

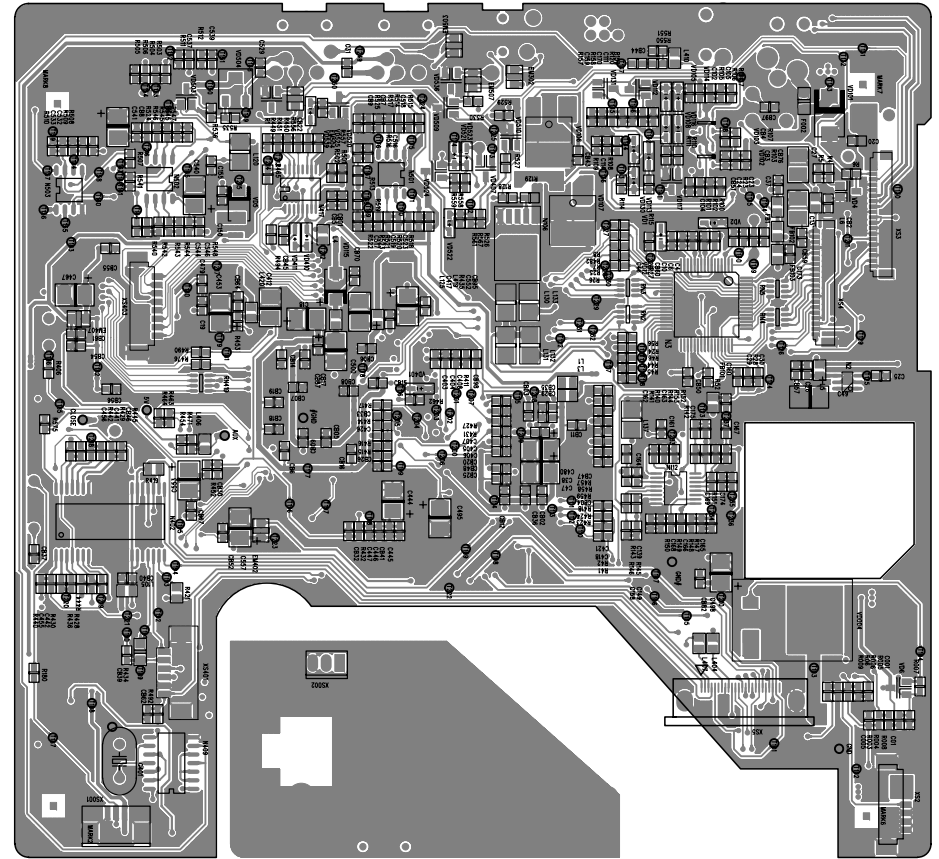
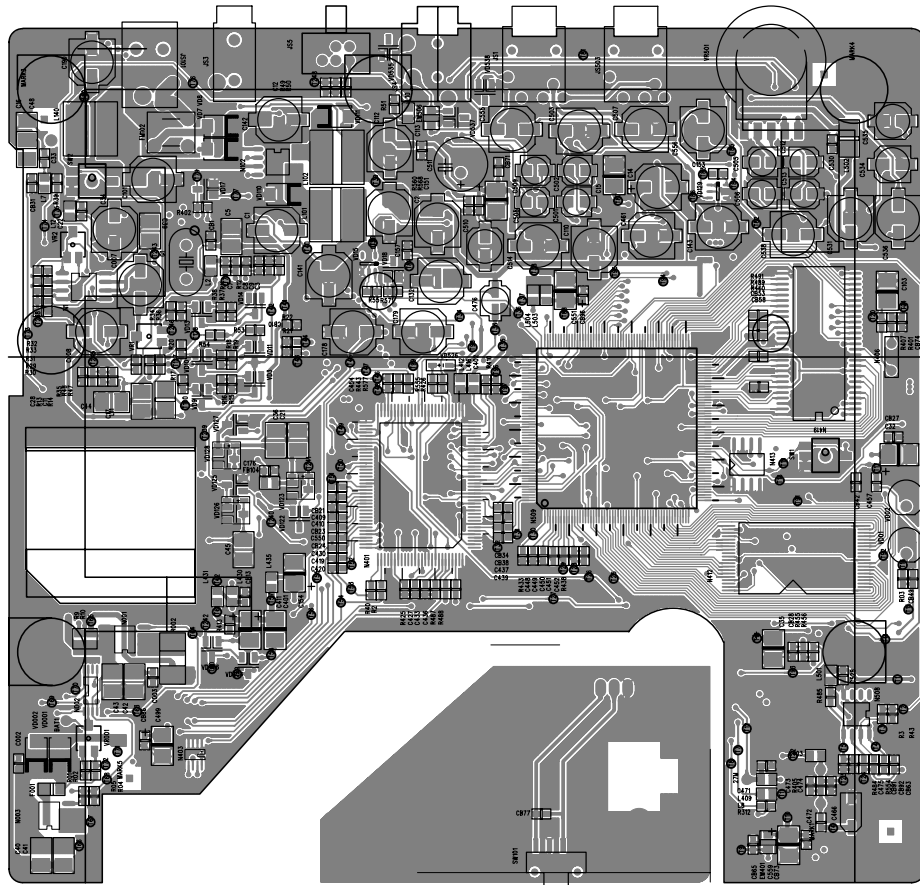

PET700 MAIN BOARD DIAGRAM

10.0 SERVICE PART LIST

Service 12NC	Model	Description	Location Code	Photo
994000000722	PET700	BATTERY	BATTERY	
994000000726	PET700	AV CABLE	AVCABLE	
994000000724	PET700	REMOTE CONTROL	RC	
994000000727	PET700	TRAVEL BAG	BAG	
994000001902	PET700	CAR CIGARTE ADAPTOR	CARADAPTOR	
994000003524	PET700/05	ADPV18A ADAPTOR /05	ACADAPTOR	
994000001898	PET700/00	ADPV18A ADAPTOR /00	ACADAPTOR	
994000002897	PET700/44	ADPV18A ADAPTOR /44	ACADAPTOR	
994000002156	PET700/75	ADPV18A ADAPTOR /75	ACADAPTOR	

10.0 SERVICE PART LIST

994000002876	PET700	MAIN PCB ASS'Y	100	
994000002875	PET700	IF PCB ASS'Y	110	
994000002878	PET700	HV PCB ASS'Y	120	
994000002877	PET700	FUNCTION PCB ASS'Y	130	
994000002891	PET700	20 PIN HARNESS (LE105)	142	
994000002892	PET700	20 PIN HARNESS (L140)	144	
994000004203	PET700	TFT LCD	200	
994000002228	PET700	DV23 LOADER	210	
994000002893	PET700	SPEAKER	220	

10.0 SERVICE PART LIST

994000002881	PET700	TOP COVER	300	
994000002882	PET700	DISPLAY FRAME	310	
994000002883	PET700	MIDDLE CABINET	320	
994000002884	PET700	BOTTOM CABINET	330	
994000002885	PET700	BASE COVER	331	
994000002988	PET700	CONTROL KEY PAD	350	
994000002886	PET700	DOOR	360	
994000003766	PET700	TOP COVER LOCK	400	
994000002338	PET700	DOOR SPRING	410	
994000002888	PET700	TOP COVER LOCK SPRING	420	
994000002887	PET700	OPEN BUTTON SPRING	430	
996500039078	PET700	ON/OFF SWITCH	OFSWITCH	
996500041639	PET700	SWITCH SW1	SW1	

10.0 SERVICE PART LIST

996510001857	PET700	LOCKING KEY ON MID CAB	440	
--------------	--------	------------------------	-----	---

11.0 REVISION LIST

Version 1.0 (3141 785 30560)
Initial release PET700/00/05/44/75

Version 1.1 (3141 785 30561)

Chapter 10:

Service parts list adapted with new parts and revised 12NC as listed below

- Added photo on speaker (994000002893)
- Deleted DVD mark (994000002889)
- Added the new part control key pad (994000002988)

Version 1.2 (3141 785 30562)

Chapter 10:

Service parts list revised 12NC as listed below

- Corrected typo of 20 PIN harness (LE105) from 9940 000 02891 to 9940 000 02891
- Changed DV23 loader from 9940 000 02894 to 9940 000 02228
- Changed adaptor/05 from 9940 000 00728 to 9940 000 02229
- Changed adaptor/00 from 9940 000 00723 to 9940 000 01898
- Added the new part Top Cover Lock (994000003766)

Version 1.3 (3141 785 30563)

Chapter 10:

- Added the new part ON/OFF SWITCH (996500039078)

Version 1.4 (3141 785 30564)

Chapter 10:

- Added 12NC of new spare part SWITCH SW1 (996500041639)
- Added location code on spare parts

Version 1.5 (3141 785 30565)

Chapter 10:

- Added 12NC of locking key on mid cabinet (996510001857)